

## TECHNICAL BULLETIN

Page 1 of 4

---

Sony #: **SCTB98-001**

Subject: **Adjustment of CCD Output Gain for the DFP-R2000**

Effected Units Model/Serial #: DFP-R2000 #10001 and higher. (All units)

---

### What is the symptom:

As with picture, proper illumination is an important parameter of the playback performance of the SDDS Reader. Illumination that is out of specification can cause your system to drop in and out of digital intermittently or randomly, which is detected by the operator as the "...sound switching between the analog back-up track and digital track...". This bulletin illustrates the recommended procedure for checking, and aligning the Reader's light output, known as the **CCD Output Gain**.

### What is the solution:

*Sony recommends that you check your Reader's CCD Output Gain every 3-6 months, or at each projector bulb replacement interval, whichever comes first. Since this adjustment will require an oscilloscope, it may be best scheduled at each projector A-Chain alignment, when the necessary test equipment is ordinarily available in the projection booth.*

### Required Equipment:

- DFP-D2000
- DFP-R2000
- CCZ-A Interface Cable
- Oscilloscope, 100MHz
- #1 Phillips Screwdriver (Vessel style preferable)
- Shorting Clips
- Alignment Tool
- Cotton Swabs
- Tech Bulletin SCTB98-001

### Maintenance Strategy:

There are two steps to maintain the light output of the DFP-R2000 Reader at normal performance specifications throughout the life of the Reader.

Procedure #1) Adjustment of the two video output level potentiometers of the Reader unit (RV8 on the RF-67 boards) on a regularly scheduled basis. This adjustment allows for the compensation of the light output of the LED assemblies. When the gain has been adjusted to its maximum value, but insufficient light output level is the result, then continue to Procedure #2.

Procedure #2) When sufficient video output level is no longer possible with procedure #1, it will be necessary to replace the LED assemblies (two used in each Reader unit) with a new set of LED assemblies (Sony part #A-8263-459-B).

Both of these procedures are explained in detail on the following pages of this bulletin.

## TECHNICAL BULLETIN

Page 2 of 4

### Procedure #1, Adjustment of CCD Output Gain:

*Note: This adjustment is performed without film threaded through the Reader.*

1. Connect the DFP-R2000 to the DFP-D2000 using the CCZ interface cable (standard interconnection).
2. Set AC power switch of DFP-D2000 to ON.
3. **Clean the Reader's optics** - the two lenses and the two light sources - with a clean, dry cotton swab. (Fig. 1)
4. Remove the screw securing the Slide Cover to the left of the Reader's front door, and **remove the Slide Cover** (Fig. 2, the screw is found on the left side of the Reader).
5. **Using a shorting clip, short between TP7 on the upper RF-67 board and the metal chassis "bracket" (GND).** Notice that this will turn on the outside, or "S" side LED (closest to the operator). (Fig. 3)
6. **Connect channel one of the oscilloscope to TP 14 on the upper RF-67 board.** Set the Volt/Div parameter of the oscilloscope to 200mV and the Sec/Div parameter of the oscilloscope to 10 $\mu$ S. Set the trigger mode to Auto, and the trigger source to channel one. You should see a signal similar to the figures below. (Fig.4-Fig.6)
7. **Adjust RV8 on the upper RF-67 board so that the average value of the waveform is 1VDC,** (or five divisions) as shown in Fig. 5 below. (*Note: Adjust only RV8*)
8. **Repeat steps 5 through 7 on the lower RF-67 board.** This will adjust the inside or "P" side illumination.
9. Re-install the Slide Cover on the Reader.

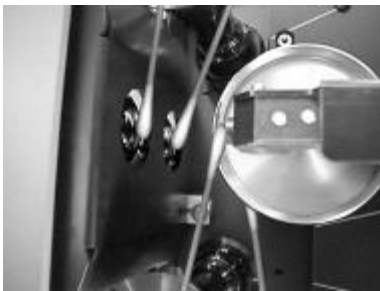

Fig. 1: Clean the Reader's optics



Fig. 2: Remove the slide cover



Fig. 3: Adjustment connections

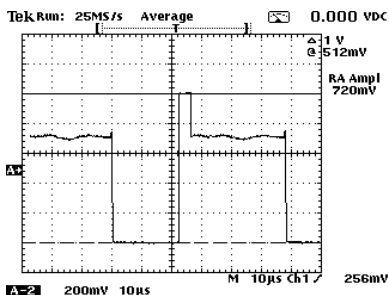

Fig. 4: CCD gain TOO LOW

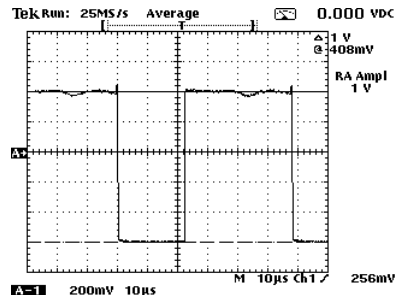

Fig. 5: CCD Gain CORRECT

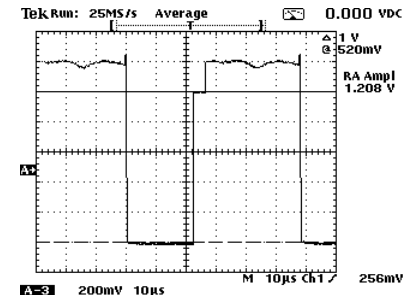

Fig. 6: CCD Gain TOO HIGH

## TECHNICAL BULLETIN

Page 3 of 4

### Procedure #1, Adjustment of CCD Output Gain (continued):

(refer to DFP-R2000 Maintenance Manual, page 3-8 & 3-9)

#### Adjustment Locations:

**NOTE:** There are two (2) RF-67 boards, two (2) SE-231 boards, and two (2) LED Assemblies (A-8263-459-B), one of each for the picture side (P-side) and the sound side (S-side) tracks. When adjusting, refer to the locations listed below.

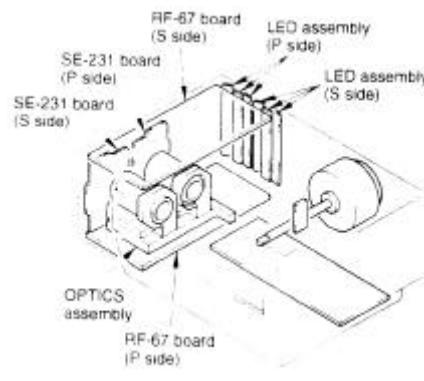

The CCD Output Gain adjustment is performed on the two RF-67 boards inside the Reader, one above and one below the optics assembly. The necessary test points for this adjustment are **TP7** (to turn on the LED), and **TP14** (to measure the CCD output level). The adjustment potentiometer to calibrate the CCD output level is **RV8**. Do not adjust any other potentiometers on the RF-67 boards!

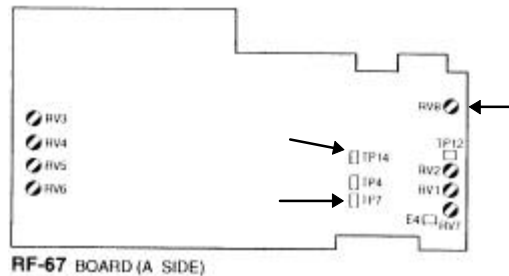

#### Oscilloscope Connection:

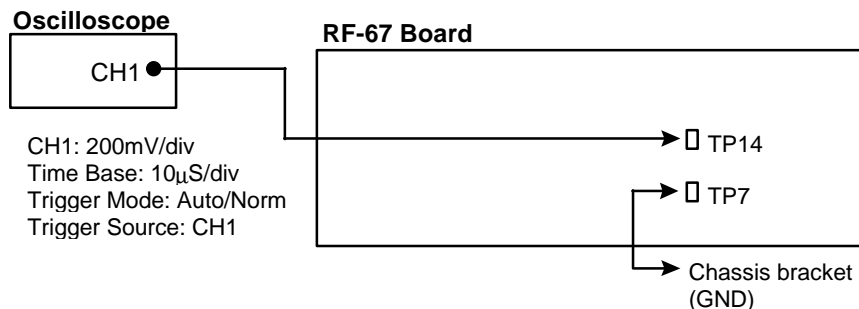

## TECHNICAL BULLETIN

Page 4 of 4

### Procedure #2, Replacement of LED Assemblies (Sony # A-8263-459-B):

(refer to DFP-R2000 Maintenance Manual, page 3-2)

Order two (2) LED assemblies (Sony # A-8263-459-B) from your Sony Service Center for each DFP-R2000 unit to be repaired. Then follow the procedure below. After the LEDs have been replaced, it is necessary to perform Procedure #1 of this bulletin, as the light output of the new LED assemblies will need to be re-calibrated for the proper gain setting. Before closing the rear of the Reader, ensure that the LED wire harnesses do not contact the Reader's flywheel.

#### Preparations

1. Turn the power OFF.
2. Remove the one fixing screw and the slide cover.
3. Remove the rear lid.

#### Replacement

1. Disconnect the three connectors and remove the two fixing screws.
2. Remove the LED assembly from the LED base.
3. Attach the LED assembly in the reverse order of the removal.

